

Important Luggage Information

Luggage Allowance

- One piece of luggage per person
- Weight must not exceed **15kgs**
- Either a suitcase or a duffle bag
- No steel framed backpacks, cricket bags or swags
- Each person must be able to lift/carry their own bag
- If sleeping bags are required, they need to fit inside each student's suitcase or duffle bag. They cannot be carried separately

Size Guide:

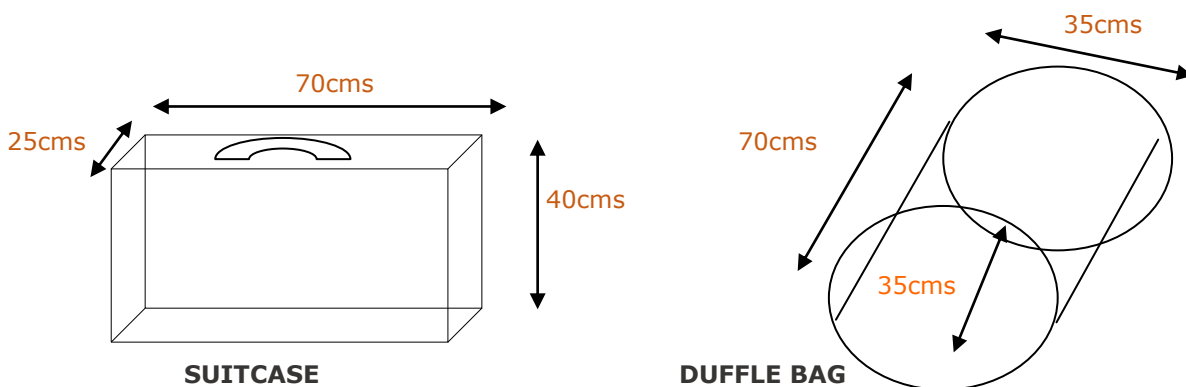

Please Note: Luggage that does not fit within the dimensions or weight limit, will not be accepted.